



# STANDARD PNEUMATIC CIRCUIT BOARDS

## CM-035

Circuit Board for R-932 Sequencing System  
Using 4 Modular Valves

Size: 7 3/4" x 2 1/2" x 13/16" thick -  
4 modules



**Use:** 4-valve sequence circuit board used as an expansion unit. #10-32 port connections provided for signal inputs, step outputs, supply and jumper connections for linking multiple boards together. May serve as final segment of circuit or be inserted between other sequencing circuit board.

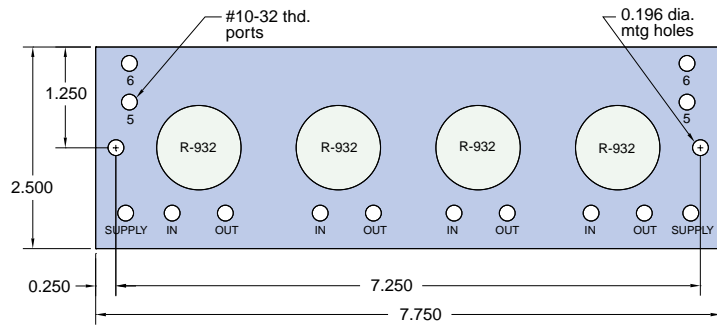
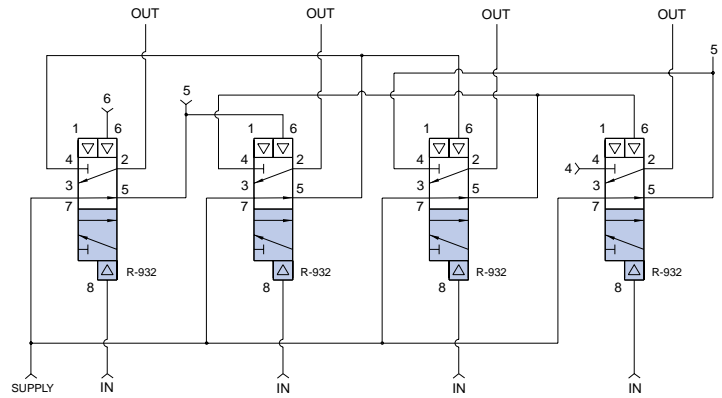

## CM-036

2-Valve Mounting Subplate with 1/8" Ports

Size: 7" x 3" x 5/8" thick - 2 modules

